

IQAN-SV

Instruction book

Publ no HY33-8414-IB/UK
Edition 2017-07-26

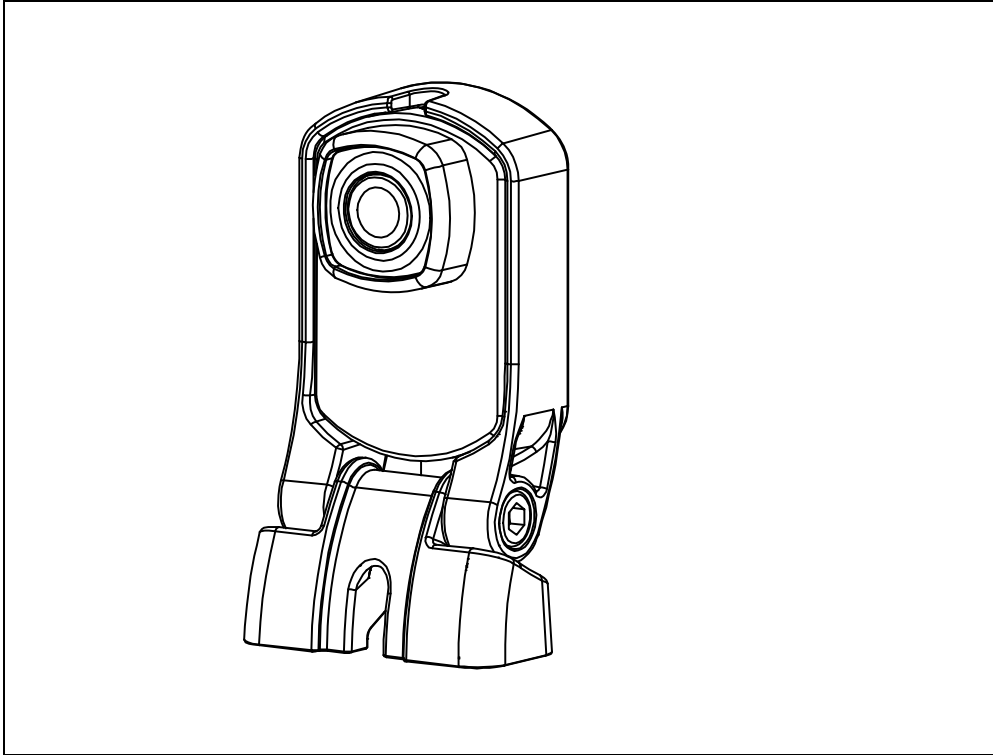

1	Introduction	1
	Safety symbols	1
2	Precautions	2
	Disposal	2
	Start-up, maintenance, and diagnostics	2
3	Quick start	3
4	Product description	4
	Features	5
	Image crop	5
	Live Indicator	6
	Maintenance and cleaning	6
	Fixing a blurry image	6
5	Markings and approvals	7
	Declaration of conformity	7
6	Mounting	8
	Mounting the IQAN-SV	8
7	Installation	9
	Connector, C1	9
	Connector pin assignments	9
	Connector, C2	9
	Connector pin assignments	9
	Supply voltage	10
	Connecting of Supply Voltage	10
	Polarity reversal	10
	Communication	11
	Ethernet connection	11
8	Start-up	12
	Start-up procedures	12
	Starting the control system	12
	Prepare for system start	12
	Start the system	12
	Appendix A	13
	IQAN-SV Technical Overview	13
	Absolute Maximum Ratings	13
	Environmental ratings	13
	System	14
	Ethernet	14
	Video	14
	Appendix B	15
	Dimensioning of the IQAN-SV module	15

1 Introduction

These instructions are to be used as a reference tool for the vehicle manufacturer's design, production, and service personnel.

The user of these instructions should have basic knowledge in the handling of electronic equipment.

Safety symbols

Sections regarding safety, marked with a symbol in the left margin, must be read and understood by everyone using the system, carrying out service work or making changes to hardware and software.

The different safety levels used in this manual are defined below.



WARNING

Sections labeled *WARNING* with a caution symbol in the left margin, indicate that a hazardous situation exists. If precautions are not taken, this could result in death, injury, or property damage.



NOTICE

Sections labeled *NOTICE* with a notice symbol in the left margin, indicate there is important information about the product. Ignoring this could result in less than optimal performance, or damage to the product.

2 Precautions

Work on the hydraulics control electronics may only be carried out by trained personnel who are well-acquainted with the control system, the machine and its safety regulations.



WARNING

Make sure that you have sufficient knowledge before designing, modifying or servicing the control system.

Read the relevant sections of this document before conducting any work on the control system.



WARNING

This product is not field repairable.



NOTICE

As much as possible of the welding work on the chassis should be done before the installation of the system. If welding has to be done afterwards, the electrical connections on the system must be disconnected from other equipment. The negative cable must always be disconnected from the battery before disconnecting the positive cable. The ground wire of the welder shall be positioned as close as possible to the place of the welding. The cables on the welding unit shall never be placed near the electrical wires of the control system.

Disposal

Observe your local/national regulations when disposing the device and its package.

Start-up, maintenance, and diagnostics

For all personnel carrying out installation, commissioning, maintenance or troubleshooting.



WARNING

Work on the hydraulics control electronics may only be carried out by trained personnel who are well-acquainted with the control system, the machine and its safety regulations.

Before you start,

Read section "Start-up", on page 12.

Additional information for service

Mounting and maintenance instruction book.



NOTICE

It is required to download the operating system 4.0 or later to enable full functionality of the camera in IQANdesign platform systems.

3 Quick start

Before using the IQAN-SV Ethernet camera, it must be connected to the IQAN-MD4 connector (C4) by an Ethernet cable.



NOTICE

Recommend using a CAT5 specification cable for best results.

A new camera installed in the IQAN application needs to be physically associated with the application in the MD4.

This is done from the menu system; System > Cameras > Select camera from list.

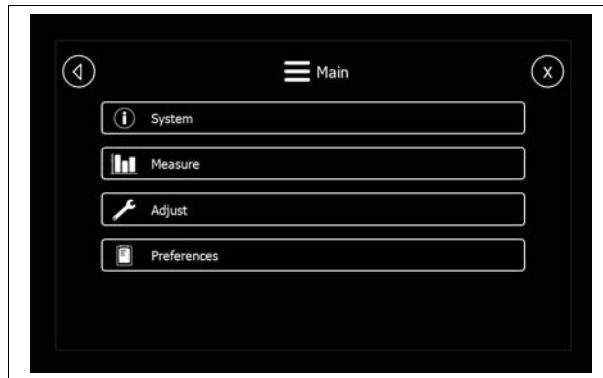

Associating a camera from the MD4 menu system, System

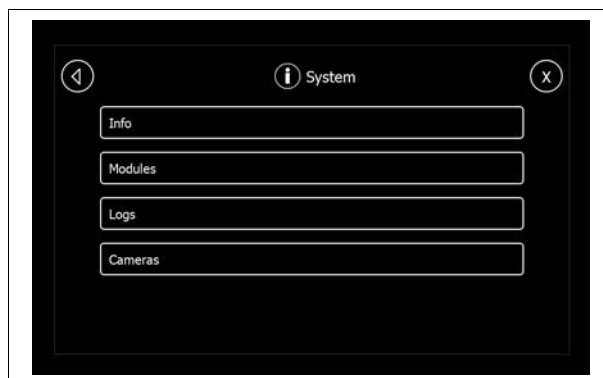

Associating a camera from the MD4 menu system, Cameras

The IQAN-SV is listed together with the camera MAC-address.

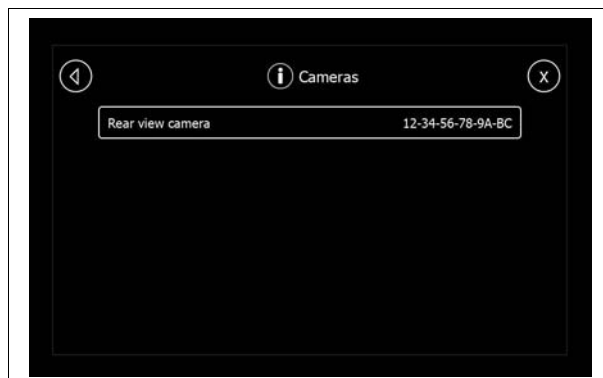

IQAN-SV camera MAC-address

4 Product description

The IQAN-SV is an IP camera that provides a vision system to vehicles using the IQAN-MD4 family of master display modules. This type of unit is a small dimension IP camera to be used as a mobile vehicle blind spot monitor or rear view camera in an IQAN control system. Each IQAN-SV can only be used with one IQAN-MD4 master display at a time, the camera's video feed cannot be routed to multiple MD4 units

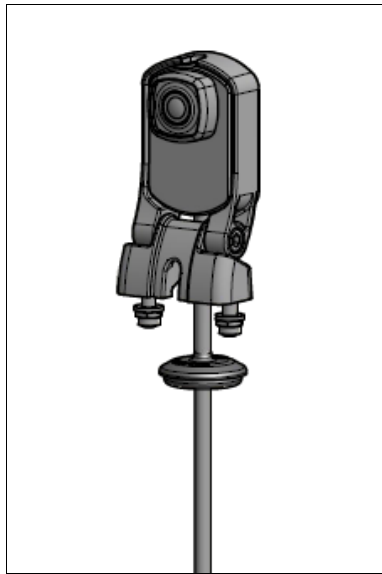

IQAN-SV camera

The IQAN-SV is a new generation of digital, high resolution IP camera using an Ethernet video link to work together with IQAN-MD4 master displays. Settings and control of the IQAN-SV camera are easily accomplished by using IQAN software for:

- Rear view
- Video size picture scaling
- Split screen view
- Easy application logic integration

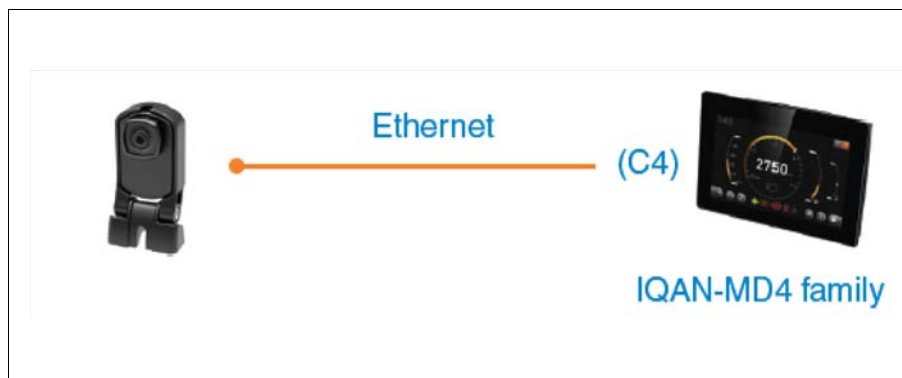

IQAN-SV camera in a system

IQAN-MD4 and the vision system is expandable to 2 cameras by using port C3 (IQAN software 4.02 and newer).

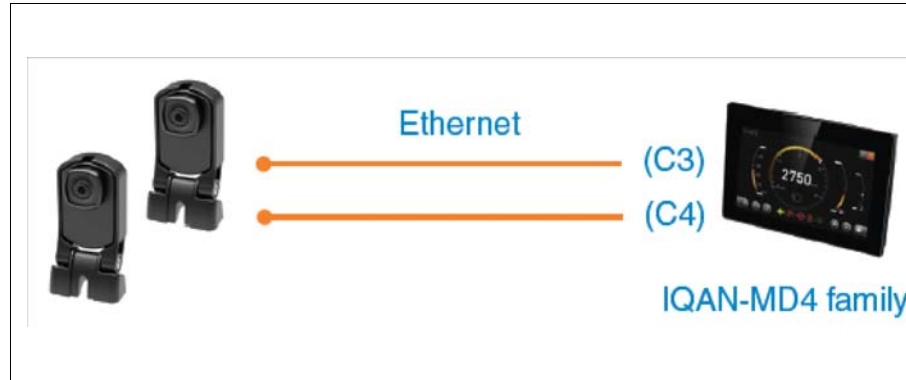

2 x IQAN-SV camera in a system

IQAN-MD4 and the vision system is expandable to a number of cameras by use of an Ethernet switch.

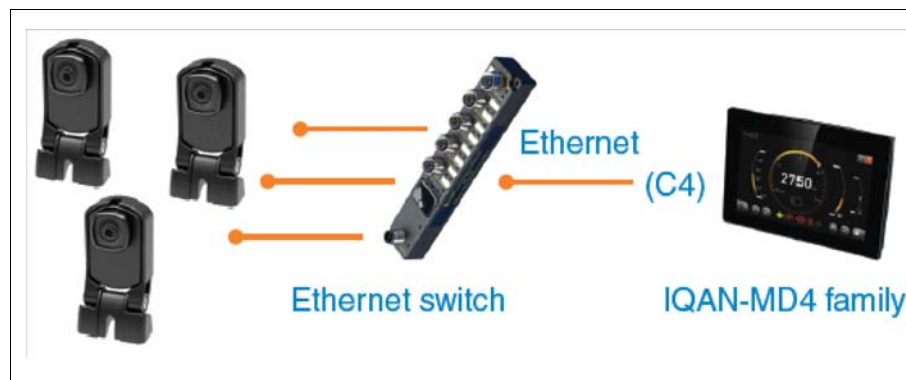

Multiple IQAN-SV cameras in a system

Features

The IQAN-SV camera has 120° field of view, excellent video quality, color and light sensitivity. The fast frame rate provides a high quality video stream with no noticeable latency.

Image crop

The camera picture can be set to different viewing pixel sizes and also a narrow mode (60 degree field of view) in IQANdesign software.

Wide mode dimension	Narrow mode
800x600	800x600
800x480	-
640x480	640x480
480x360	-
320x240	320x240
240x176	-
160x120	160x120

Live Indicator

The camera has a 'live' indicator that can be turned on and off in IQANdesign software, to indicate live video streaming. It appears as a round circle in the right left corner of the video image window on the MD4 display.

Maintenance and cleaning

Fixing a blurry image

If the camera image is blurry, it is advisable to clean the camera.

Cleaning the lens glass

Use a soft cloth to clean the lens glass of the camera. Use clean water or a high quality, safe foam cleaner. Rub the camera lens glass clean with the cloth. Absolutely do not use aggressive chemicals or abrasive cleaning agents.

5 Markings and approvals

Declaration of conformity



Declaration of Conformity

We: Parker Hannifin Manufacturing Sweden AB
Electronic Controls Division

Located at: Mölnlycke Fabriker 14
S-435 35 Mölnlycke, SWEDEN
Tel. +46 31 750 44 00

Declare that the products identified herein comply with the essential requirements of the following EU directives:

2014/30/EU **EU EMC Directive**

2011/65/EU **EU RoHS II Directive**

Harmonized standards:

ISO 14982:2009 Agricultural and forestry machines - Electromagnetic compatibility - Test methods and acceptance criteria

EN 13309:2010 Construction machinery - Electromagnetic compatibility of machines with internal electrical power supply

EN 50581:2012 Technical documentation for the assessment of electrical and electronic products with respect to the restriction of hazardous substances

Trade Name: Electrohydraulic Control Systems

Products: **IQAN-SV - 120**

Signature of responsible party:

A handwritten signature in blue ink, appearing to read "Håkan Jisland".

Printed name of responsible party: Håkan Jisland
Position of responsible party: Operations Manager

Executed on July 1st 2017, at Mölnlycke, Sweden

6 Mounting

Mounting the IQAN-SV

The IQAN-SV is designed for outdoor use on mobile machinery. The enclosure is sealed for outdoor use and the camera is robust to handle heavy vibrations and other stresses found in mobile equipment. The connector is a sealed 4 position M12 type mounted on a 500 mm long cable. There is also a 2 position Deutsch DTM connector to supply power to the camera.

The anodized aluminum camera housing and glass-filled nylon bracket is designed for easy mounting using 2 screws. A supplied grommet protects the cable from sharp edges of the vehicle chassis. The IQAN-SV is fully adjustable to accommodate any mounting location and capture the desired field of view.



NOTICE

Mounting of the IQAN-SV camera as a solution for back-up camera or side view mirror needs to be permitted by country / region standards

The IQAN-SV should be mounted according to the following instructions:

- Locate the camera eliminating the risk for the cabling to be folded, crushed or damaged in any way. Ensure the cabling cannot pull, twist or induce sideload on the connector.
- Locate the camera so that severe physical impact is avoided, e.g impact from falling objects or the module being used as a handle for climbing on the vehicle.
- Locate the module so that air can circulate to eliminate excess heat. Ensure that no external heat, e.g. from the engine or heater, is transferred to the module.
- Locate the module so that the field of view is not obstructed.



NOTICE

The IQAN-SV must not be placed in any marine related or similar continuously damp, salt-spray environment without external protection.

7 Installation

Connector, C1

Cable kit
Type M12

Parker no. TBD

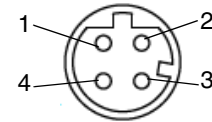

Connector pin assignments

Logical Symbol	Pin No.	(I)input or (O)utput	Function description and/or Signal name(s)
+TX	1	-	+ Transmit
+RX	2	-	+ Receive
-TX	3	-	- Transmit
-RX	4	-	- Recieve

Connector, C2

Mating connector kit
Housing, C1
Pin type (gold)
Wedge type

Parker no. 20085109
Deutsch no. DTM06-2S
Deutsch no. 1062-20-0144
Deutsch no. WM2S

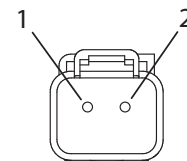

Connector pin assignments

Logical Symbol	Pin No.	(I)input or (O)utput	Function description and/or Signal name(s)
-BAT	1	-	Power supply, negative ground.
+BAT	2	-	Power supply, positive battery.

Supply voltage



WARNING

Before any installation of the IQAN system can take place, make sure the ignition lock is turned off and the battery is disconnected.

Connecting of Supply Voltage

The supply voltage, should be within the operating range, see Appendix A, on page 13. Connect the supply voltage to +BAT, position 2 and -BAT, position 1. Protect the module by using a fuse. Requisite fuse level should be 1 A, fast (F).

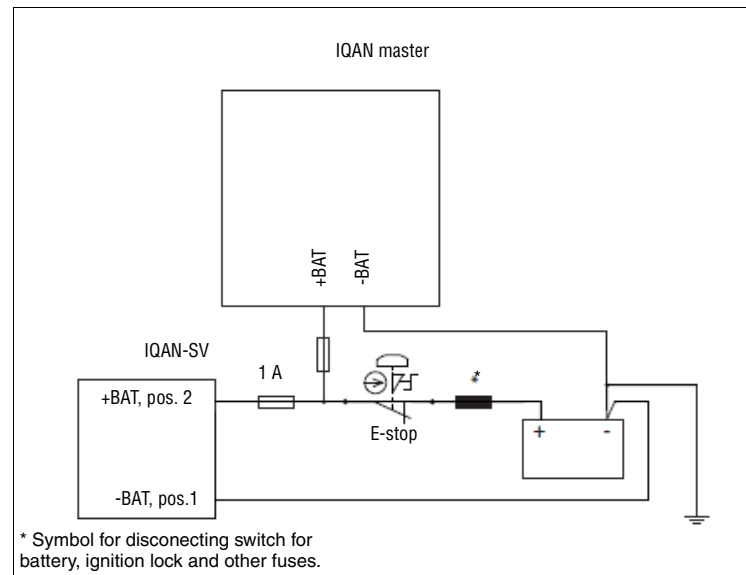

Connecting the voltage supply.



NOTICE

Connect the camera to the same power and ground as the IQAN master.

The power supply must be common to both the camera and the master unit to ensure trouble free communication. Most importantly, the ground connection (-BAT), must be the same.



NOTICE

Do not use the chassis as the negative terminal.

Polarity reversal

The IQAN-SV module is protected against power supply polarity reversal, provided an external fuse, max 1 A (Fast) is being used.

If this fuse is not used, polarity reversal can damage the unit.



WARNING

Do not connect the housing to Ground externally. This will suspend the reverse voltage protection of the power supply. Applying a reverse voltage in this case will destroy the supply circuits.

Communication

The IQAN-SV camera has plug-and-play functionality. All addressing is handled automatically by IQAN software. There is no need for time consuming, complex IP address allocation.

Ethernet connection

It is recommended to use CAT5 cable to connect the IQAN-SV to the MD4 using the following guidelines:.

- Do not lay the Ethernet cable close to or in parallel to current carrying cables. This can cause an induction field and has impact on the functionality or can cause a malfunction.
- Use the shortest possible cable route.

8 Start-up

Start-up procedures

This chapter contains instructions for action to be taken in connection with the initial start.



WARNING

Risk of injury!

If the control system is not fitted properly, the machine could move uncontrollably. The machine's engine shall not be started before the control system is completely fitted and its signals are verified.

Starting the control system

Start the control system as follows:

- Prior to start, all modules and cables are to be fitted correctly.
- Check fuses, i.e. make sure that the supply voltage to the modules is equipped with the correct fuse.
- Make sure that connections for supply voltage and return lines are correct in the cable's conductor joint.
- Make sure an emergency stop is installed.
The emergency stop should disconnect the supply voltage to all modules. Alternatively, the emergency stop may also shut off the diesel engine or a dump valve, and with that, depressurize the hydraulic system.

Prepare for system start



WARNING

Make sure no one is in dangerous proximity to the vehicle to avoid injuries when it starts.

Prepare for the initial system start as follows:

- The engine for the hydraulic system's pump shall be in off position.
- Make sure that all connectors are properly connected.
- Turn on the control system.
- Make sure that voltage is being supplied to all modules; the power/status diode shall be illuminated on all modules. Also, make sure that the master is in contact with all modules by reading the master's display.
- Make sure the emergency stop is functioning properly.

Start the system

Start the system as follows:

- Start the engine for the hydraulic system's pump, assuming that the above mentioned inspections have been carried out and shown correct values.
- Calibrate and adjust input and output signals according to the instructions related to the master menu system and check each and every output function carefully.

Appendix A

IQAN-SV Technical Overview

Absolute Maximum Ratings^a

Parameter	Remark
Ambient temperature, T _{AOP}	-40 to 85 °C
Storage temperature, T _{AST}	-40 to 105 °C
Voltage supply on +BAT	6.5 - 36 V
Voltage on any pin with respect to -BAT	36 V

a. The “Absolute Maximum Ratings” table lists the maximum limits to which the device can be subjected without damage. **This doesn't imply that the device will function at these extreme conditions**, only that, when these conditions are removed and the device operated within the “Recommended Operating Conditions”, it will still be functional and its useful life won't have been shortened.

Environmental ratings

Parameter	Remark
EMC ISO 13766:2010/ISO 14982:2009, Radiated emission EN 55025:2008, Conducted emission ISO 11452-4:2005, Conducted susceptibility ISO 11452-2:2004, Radiated susceptibility ISO 11452-2:2004, Radiated susceptibility ISO 7637-2:2004, Conducted transients susceptibility ISO 7637-3:2007, Conducted transients susceptibility	0.15-108 MHz, Class 1 1 - 200 MHz, 1 kHz, 80% AM, 150 mA 200-2000 MHz, 1kHz, 80% AM, 100 V/m 800-2000 MHz, PM 577 us / 4.6 ms, 60 V/m Pulse 1, 2a, 2b, 3a, 3b, 4, Level 3 Pulse 5, Level 1 Level 3
ESD ISO 10605:2008, ESD operation ISO 10605:2008, ESD handling	8 kV (contact), 15 kV (air) 8 kV (contact)
Mechanical environment IEC 60068-2-64: 2008 Fh, Random vibration IEC 60068-2-27:2008 Ea, Bump	15 - 1000 Hz, 7.1 Grms, 3 x 10 h 40 g, 6 ms, 1000 * 6 dir
Climate environment IEC 60529:2001 ; DIN 40050 Part 9:1993, Water and dust IEC 60068-2-52:1996 Kb, Salt mist IEC 60068-2-30:2005 Db, Damp heat, cyclic IEC 60068-2-78:2001 Cab, Damp heat, steady state IEC 60068-2-2:2007 Bb, Heat, operation IEC 60068-2-2:2007 Bb, Heat, storage IEC 60068-2-1:1993 Ab, Cold IEC 60068-2-14:1984 Nb, Change of temperature	IP67 : IP6K9K 72 hr. +55°C, 95% RH, 6 cycles +40°C, 93% RH, 21 days +85°C, 72 hours +105°C, 72 hours -40°C, 16 hours -30°C to +55°C, 10 x 8 hours

System

$T_A = +25\text{ °C}$ (unless otherwise specified)

Parameter	Remark
Weight	210 g
Recommended operating temperature, T_{ROC}	-40 to 85 °C
Voltage supply, V_{BAT}	9 - 32 V
Current consumption $V_{BAT} = 14\text{ V}$ $V_{BAT} = 28\text{ V}$	typical 100 mA typical 60 mA
Start up time	typical 4 sec.

Ethernet

Parameter	Remark
Number of Ethernet connections	1
Network interface	100 Base-TX
Network protocols	ISO17215, IEEE1722, RTP over UDP, RFC2435
Communication rates	100 Mbps

Video

Parameter	Remark
Sensor element	1/3" CMOS, 1280 x 960 pixels
Iris angle	120°
Light sensitivity	< 0.1 lux
Video signal	30 fps
Video format	MJPEG
Video latency	max 300 ms

Appendix B

Dimensioning of the IQAN-SV module

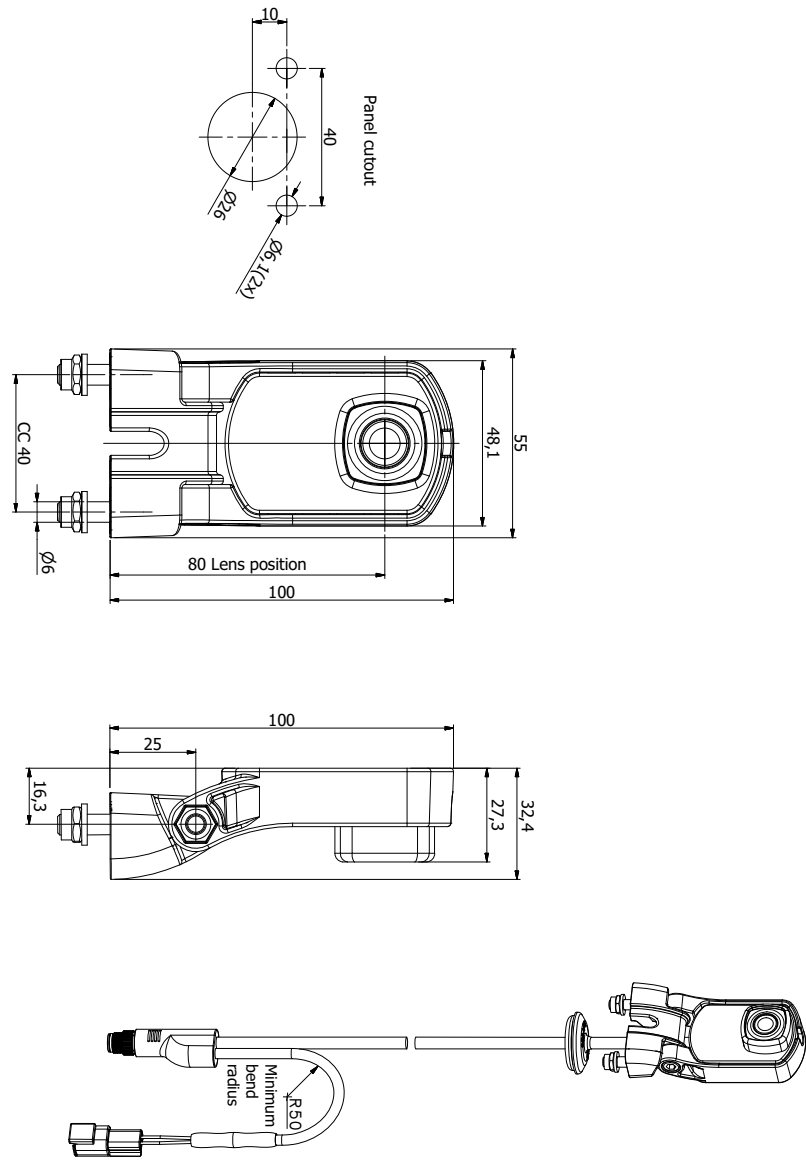

Unit = mm

For latest information visit our website www.iqan.com

Information in this instructionbook is subject to change without notice

Parker Hannifin
Mobile Hydraulic Systems
SE-435 35 Mönlycke
Sweden
Tel +46 31 750 44 00
Fax +46 31 750 44 21
www.parker.com/ecd

Parker Hannifin
Electronic Controls Division
1651 N. Main Street
Morton, IL 61550
USA
Tel +1 309 266 2200
Fax +1 309 266 6674

Publ no HY33-8414-IB/UK
Edition 2017-07-26

